

**BROAD BAND FREQUENCY  
DOWN CONVERTER and MIXER  
MODULE FOR THE HP 8568B  
SPECTRUM ANALYZER**

## Product Description

The DC-100 extends the frequency coverage for the HP8568B Spectrum Analyzer. The stock HP8568B covers 100hz to 1.5GHz. By adding the DC-100 frequency coverage of the HP8568B is extended past 4.5GHz.

With the combination of the DC-100 and the existing internal RF relay the HP8568B is transformed into a three band instrument. The fundamental band remains unchanged from 100hz to 1.5GHz. The mixer Module is not preselected so two new bands are created.

The first added band is from 1100 to 2700MHz. the second added band is from 3000 to 4500MHz. The gap between the two bands can be swept through [but not "centered" on] via 1st LO oversweep. The DC-100 plugs into the internal card cage of the 8568B and the mixer module is mounted in the RF section.



DC100 CARD and companion CONVERTER MODULE

### Typical Electrical Specifications, $T_A = +25\text{ C}$

Parameter	Specification	Units
Input frequency range of Converter Module	1000 -5000	MHz
Output Frequency of DC-100	21.4	MHz
Conversion Loss of Converter Module ( Typical)	-8	dB
Overall Gain of Converter and DC-100 (RF in to 21.4Mhz OUT)	10 Typical	dB
BAND 1 Coverage ( Fundamental band, unchanged)	100Hz to 1.5GHz	-
BAND 2 Coverage	1100 to 2700 (to 3000 with over range)	MHz
BAND 3 Coverage	3000 to 4500(to 5200 with over range)	MHz
2xLO +/- 2xRF & LO+/-2RF Spurious Response, Bands ** ( Typ)	- 45	dBc
2xLO +/- 2xRF Spurious Response, Bands 3 ( Typ)	-30	dBc
1dB Compression, Bands 2&3	-15	dBm
Gain Flatness , Band 2, 1100 to 2300MHz	+/- 1.5 Typical	dB
Roll Off from Mid Band Level , Band 2, 2300 to 2800 MHz	3	dB
Gain Flatness Band 3, 3000 to 4500MHz	+/- 1.5 Typical	dB
Roll Off from Mid Band Level , Band 3, 4500 to 5200 MHz	3	dB
Max Span, All Bands	1500 (1700 with over range)	MHz
Frequency Accuracy, Bands 2&3	+/- 30 , +/- 10 Typ.	KHz
Minimum usable RBW bands 2&3	300	Hz

\*\* 2.8GHz Low Pass Filter on HP 8568B Input, I.L. ~ 4 dB

For price, delivery, and to place orders, please contact DKD Instruments:  
750 Amber Way, Nipomo, CA 93444 Phone: 805-929-2285  
Visit us at [www.dkdst.com](http://www.dkdst.com) or Email us at: [info@dkdst.com](mailto:info@dkdst.com)

## BLOCK DIAGRAM OF HP8568B WITH AND WITHOUT DC100/CONVERTER

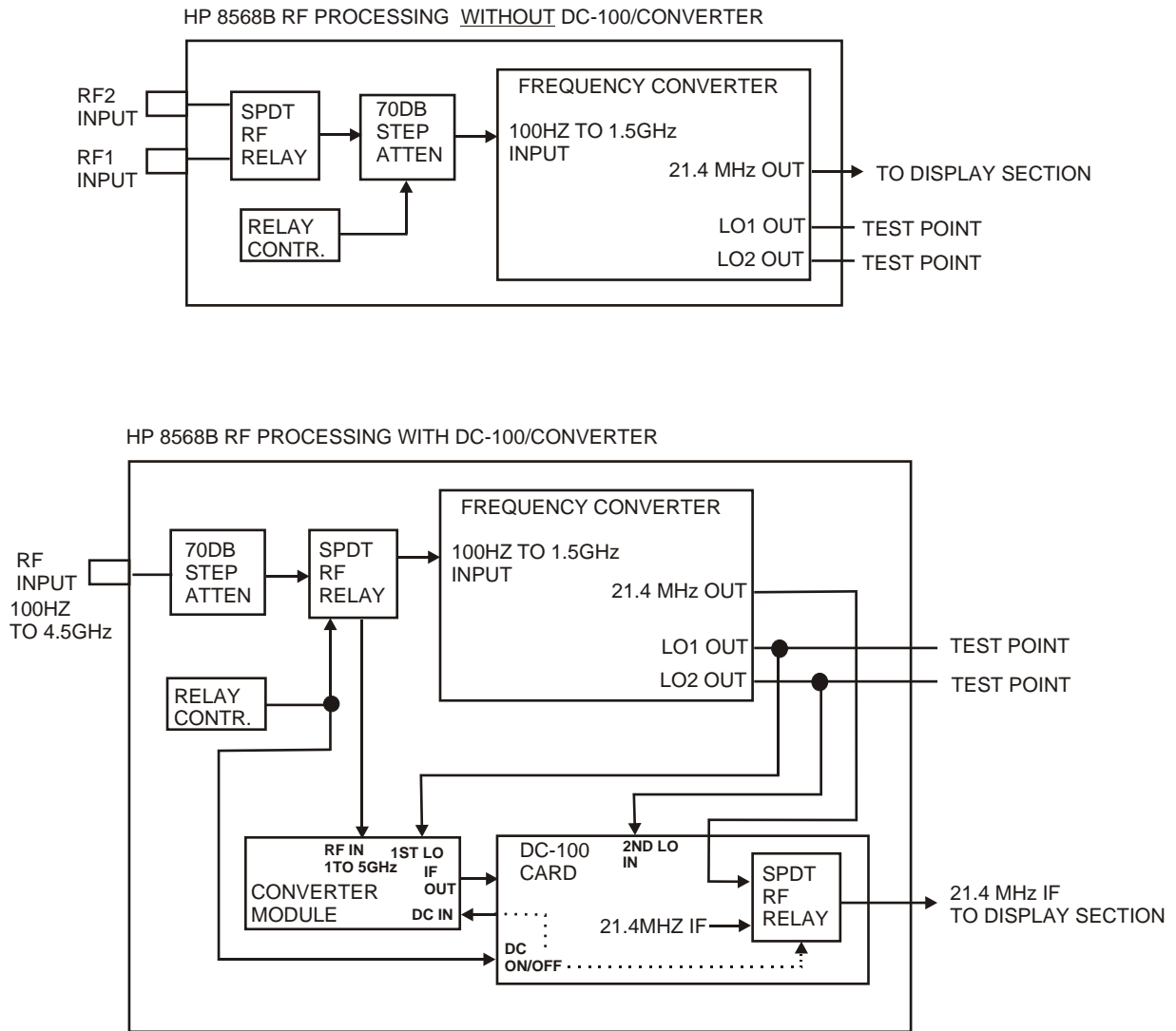

### NOTES:

1. NO IRREVERSIBLE CHANGES ARE DONE TO THE 8568B TO INSTALL THE DC-100 SYSTEM.
2. PERFORMANCE OF ORIGINAL BAND IS UNCHANGED.
3. DURING BAND 1 OPERATION DC100/CONVERTER MODULE ARE TURNED OFF.
4. LO1 AND LO2 ARE NOT PHASE LOCKED AS USED FOR DC100. THIS DEGRADES DRIFT. & PHASE NOISE AS COMPARED TO BAND1 OPERATION.

*For price, delivery, and to place orders, please contact DKD Instruments:  
750 Amber Way, Nipomo, CA 93444 Phone: 805-929-2285  
Visit us at [www.dkdist.com](http://www.dkdist.com) or Email us at: [info@dkdist.com](mailto:info@dkdist.com)*

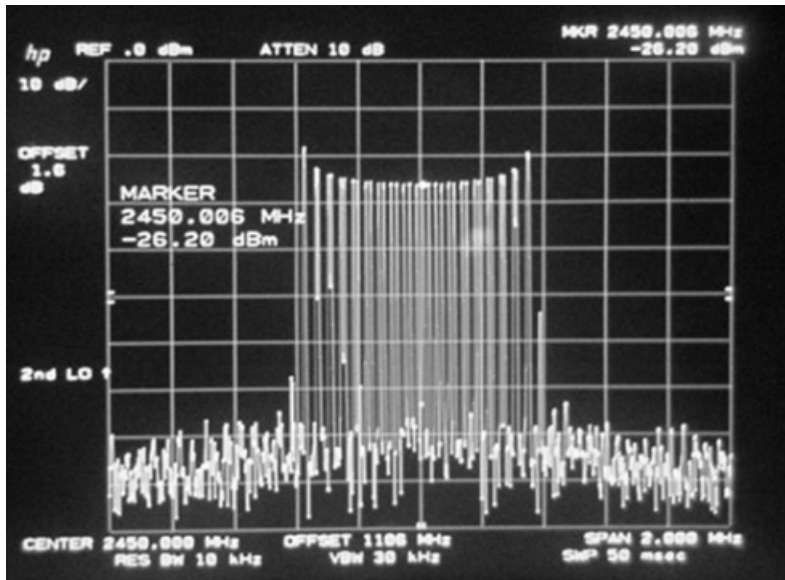

Band 2 Sample Spectrum #1

Wide Band FM Modulation on 2450 MHz Carrier.

2.8GHz LPF on Input, I.L. ~ 4dB

SPAN: 2MHz

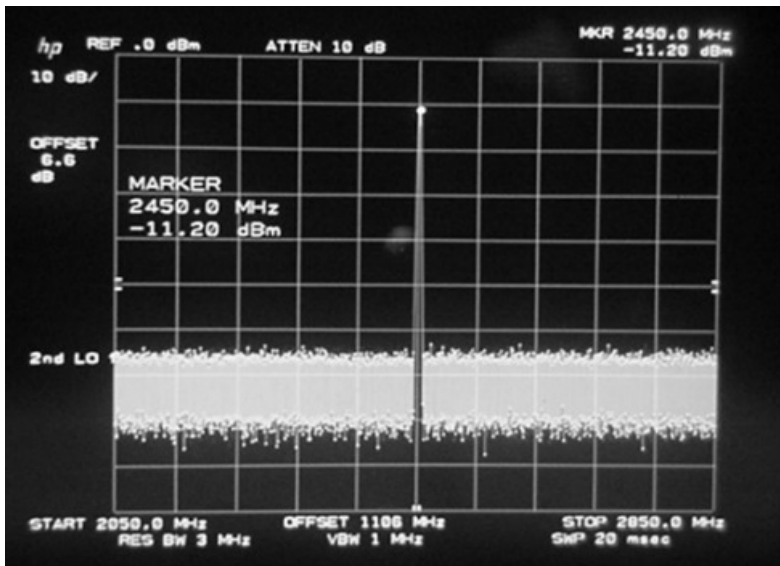

Band 2 Sample Spectrum#2

2450 MHz Carrier@ -10dBm

2.8GHz LPF on Input  
I.L. ~ 4dB

SPAN: 800MHz

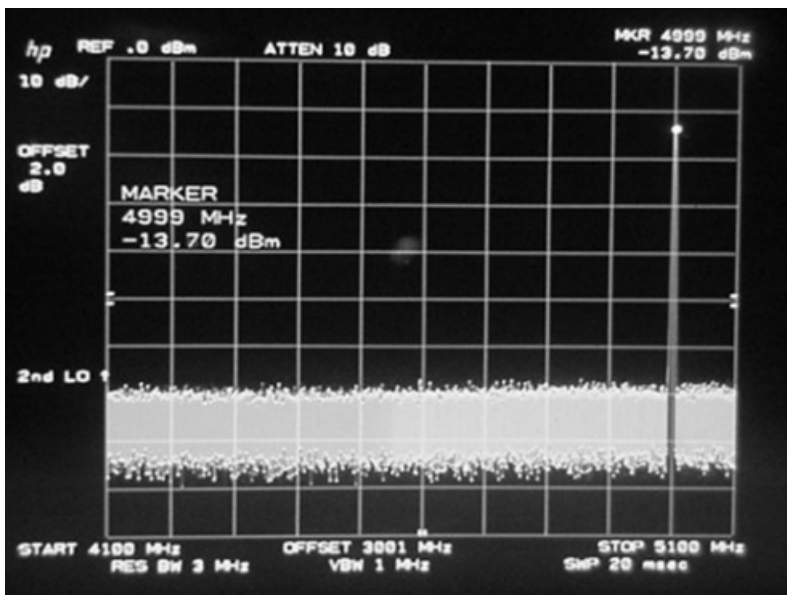

BAND 3 Sample Spectrum

5.0 GHz Carrier@ -10dBm  
(~-3db wrt mid band)

No filter on Input.

SPAN: 1000MHz

1st LO is in Over Range